

# 9658096PCCOMUK

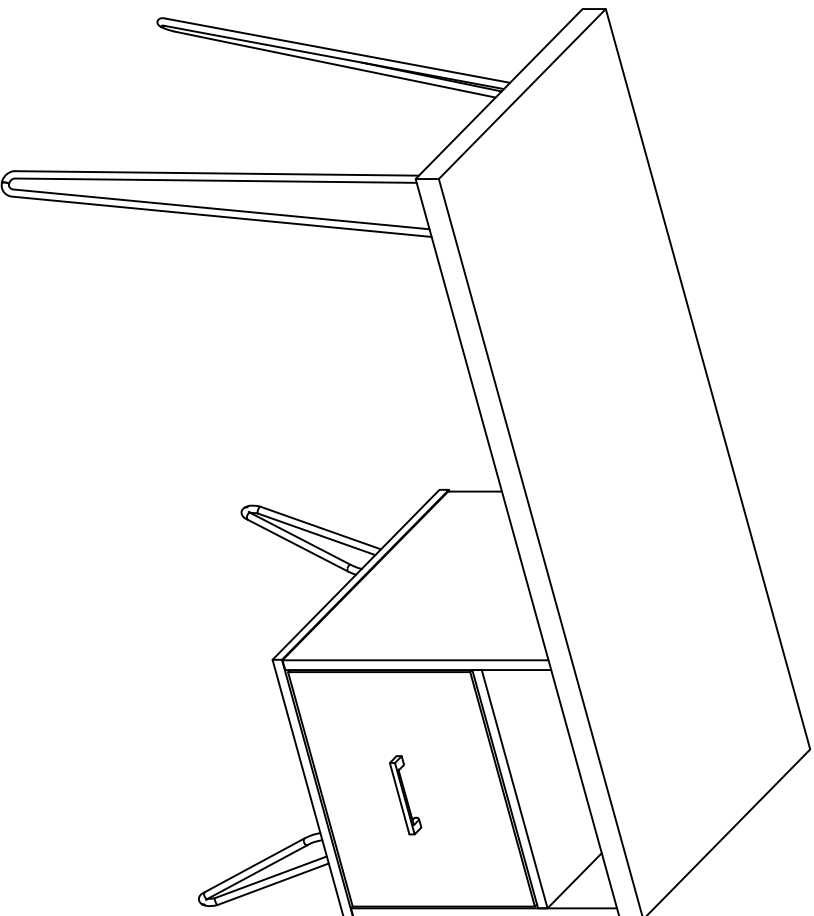

THIS INSTRUCTION BOOKLET CONTAINS **IMPORTANT** SAFETY INFORMATION. PLEASE READ IT CAREFULLY AND KEEP FOR FUTURE REFERENCE.

## Do Not Return This Product!

Contact our customer service team for help first.

Call: 01942 524100

Visit: [CSEurope@dorel.com](mailto:CSEurope@dorel.com)

Dorel Home Furnishings Europe Ltd.  
Building 4, Imperial Place, Maxwell Road  
Borehamwood WD6 1JN United Kingdom

## **WARNING**

- Unit can tip over causing severe injury or death.
- Anchor unit to stud in wall (if instructed to).
- Do Not allow children to climb on unit.
- Put heavy items on lower shelves or drawers.

Recommended no. of people needed for assembly : 2

## Before starting

- Read each section carefully before starting. It is very important that each step is performed in the correct order. If these steps are not followed in sequence, assembly difficulties will occur.
- Make sure all parts are included. Most board parts are labeled or stamped on the raw edge.
- Work in spacious area, preferably on a carpet, near the place the unit will be located.
- Have the following tools close at hand.
- Do not use power tools to assemble your furniture. Power tools may strip or damage the parts.

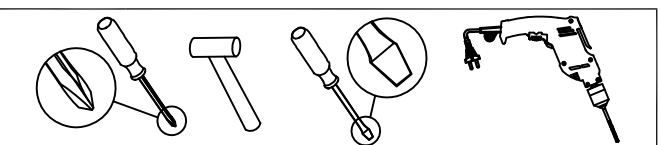

## HELPFUL HINTS

- Identify, sort and count the parts before beginning assembly.
- Compression dowels should be tapped in with a rubber mallet.
- Slides have a lip on the right side only.
- Back panels provide stability and support.
- Unit may collapse without the back panel installed.
- Clean the product with your choice of furniture polish and a soft cloth. **DO NOT USE** harsh chemicals or abrasive cleaners.
- Move your new furniture carefully. Two people are needed to lift and carry the unit to its new location.
- Never push, drag or scoot your furniture (especially on a carpet).

## Cam Lock Fastening System

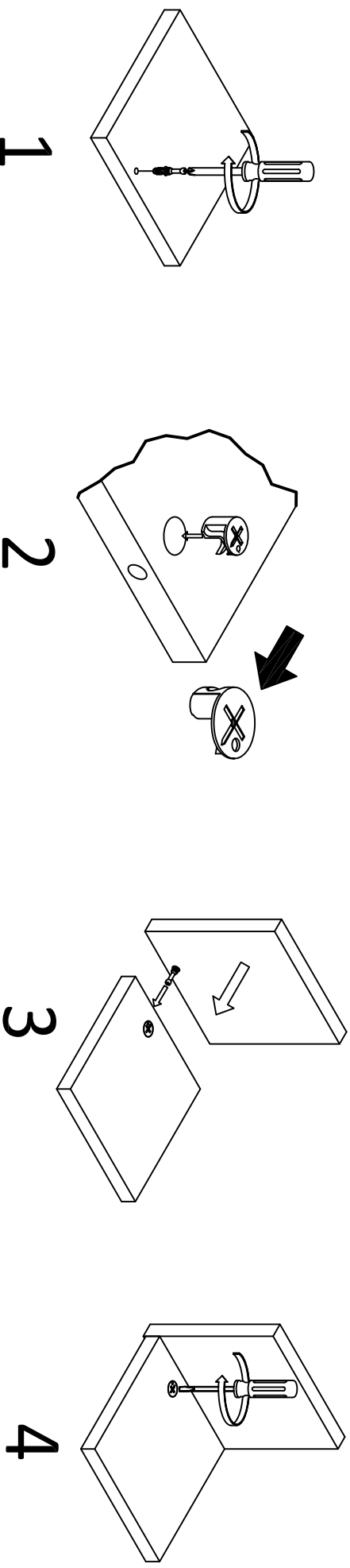

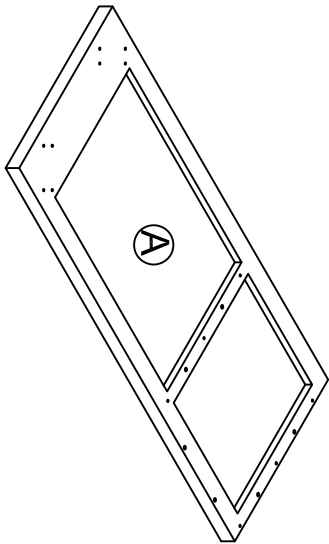

TOP  
T9658096010CS

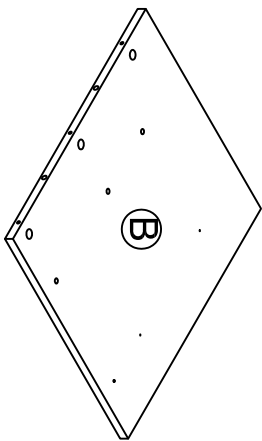

LEFT SIDE PANEL  
T9658096020CS

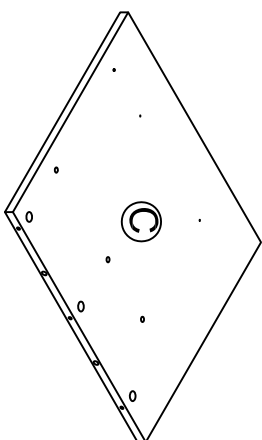

RIGHT SIDE PANEL  
T9658096030CS

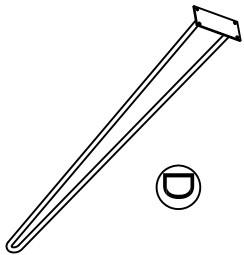

LONG LEG  
T9658096040CS  
QTY: 2PCS

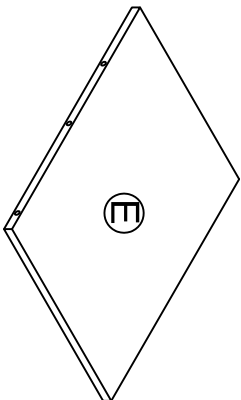

FIXED SHELF  
T9658096050CS

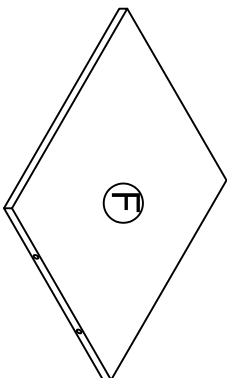

BACK PANEL  
T9658096060CS

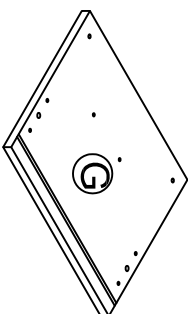

DRAWER FRONT  
T9658096070CS

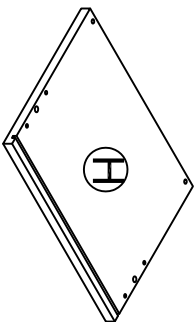

DRAWER BACK  
T9658096080CS

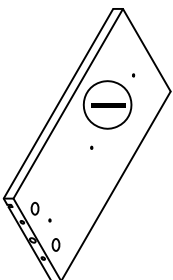

LEFT DRAWER SIDE  
T9658096090CS

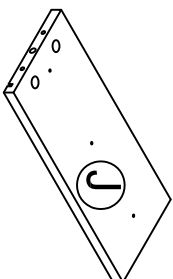

RIGHT DRAWER SIDE  
T9658096100CS

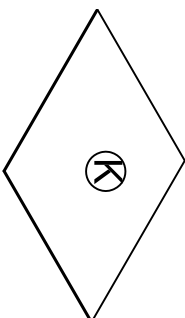

DRAWER BOTTOM  
T9658096110CS

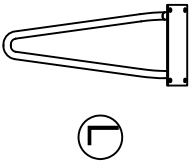

SHORT LEG  
T9658096120CS  
QTY: 3PCS

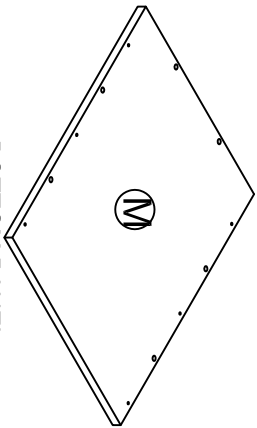

BOTTOM PANEL  
T9658096130CS

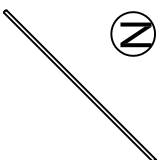

METAL FILE HOLDER  
T9658096140CS  
QTY: 2PCS

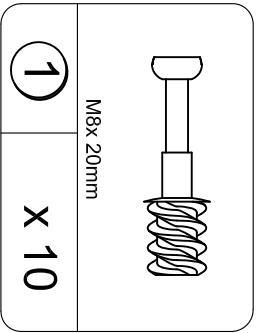

CAM BOLT  
TCS2010

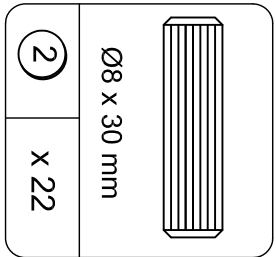

WOOD DOWEL  
TCS3002

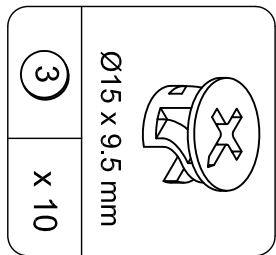

CAM LOCK  
TCS2011

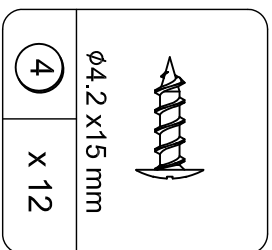

SCREW  
TCS1065

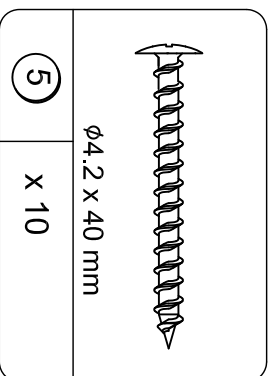

SCREW  
TCS1061

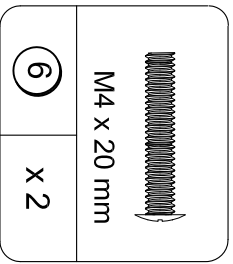

BOLT  
TCS1088

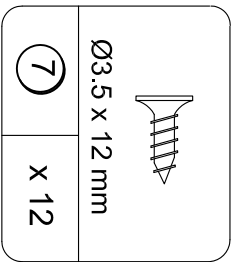

SCREW  
TCS1044

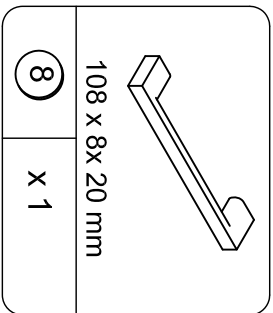

HANDLE  
TCS6601

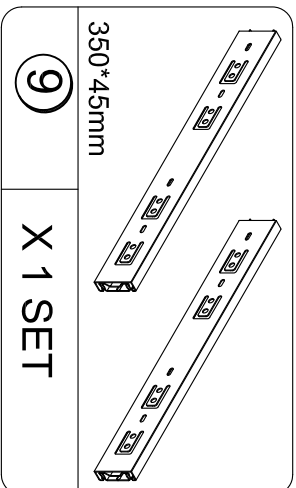

METAL SLIDE  
TCS5503

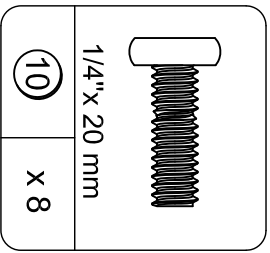

BOLT  
TCS1114

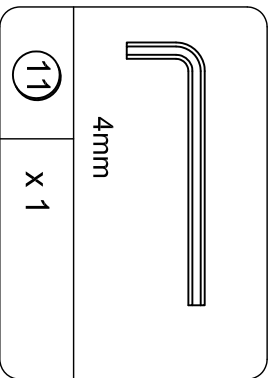

HEX KEY  
TCS6001

# HOW TO SEPARATE BALL BEARING SLIDE.

# 1

- 1) Pull toward arrow to open the slide until its stops and then flip it over.
- 2) Push plastic lever down and pull apart.

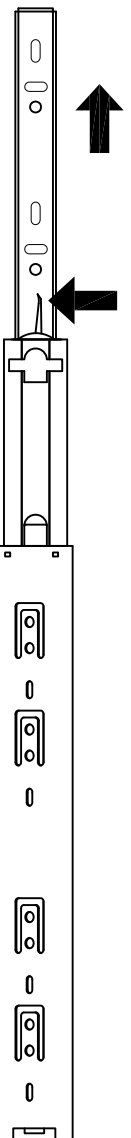
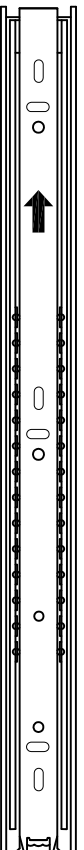

Cabinet member

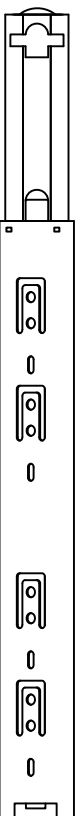

Drawer member

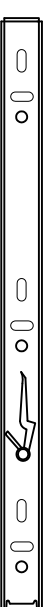

# 2

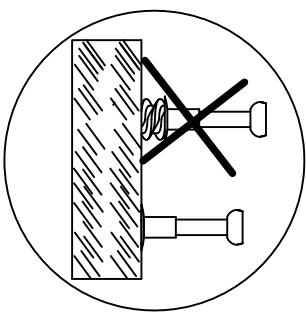
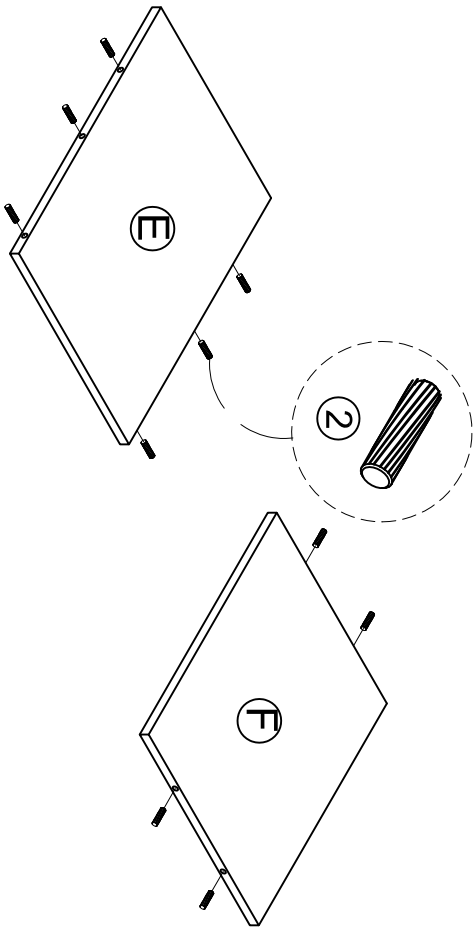
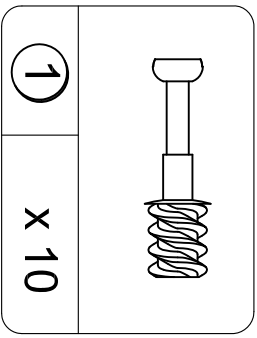
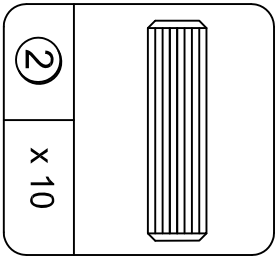
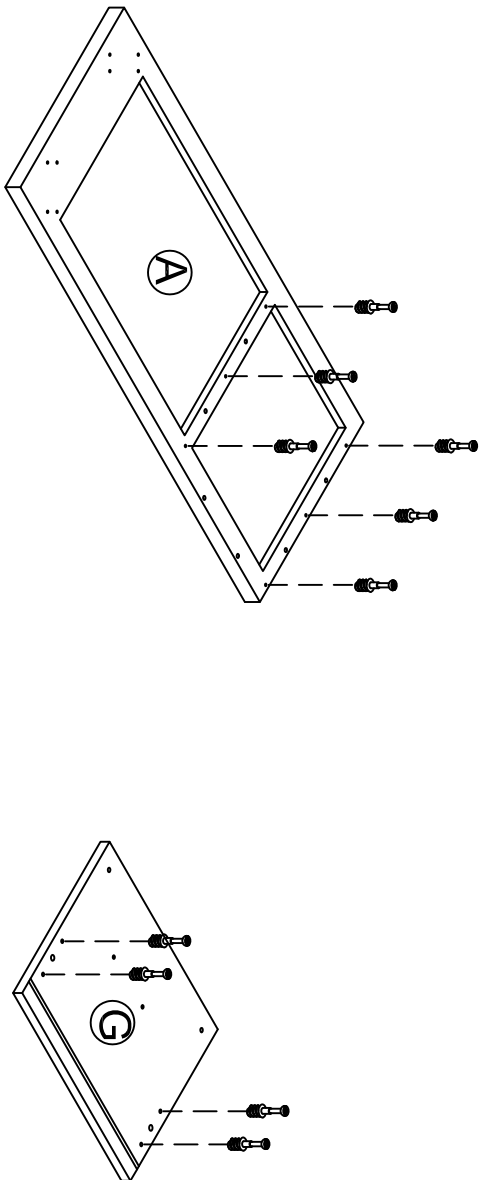

# 3

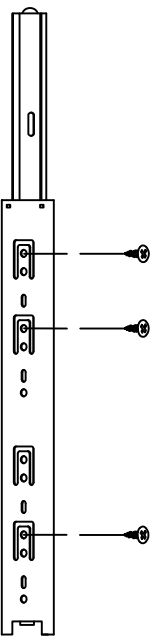
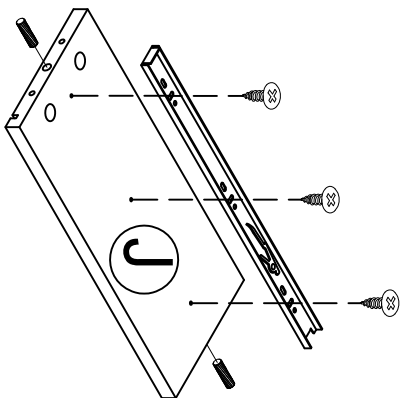
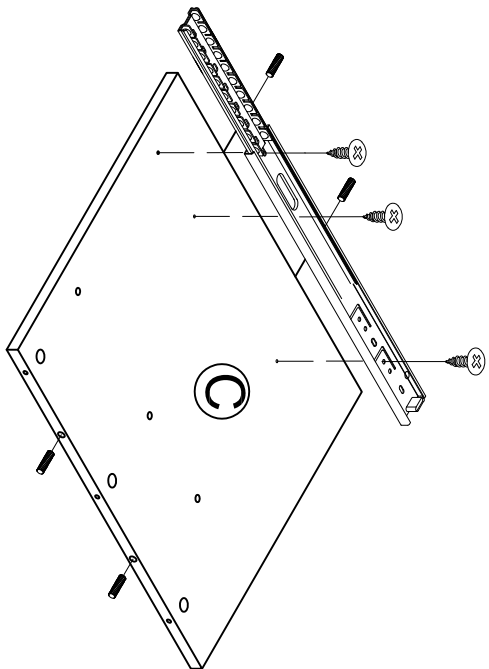
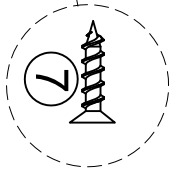
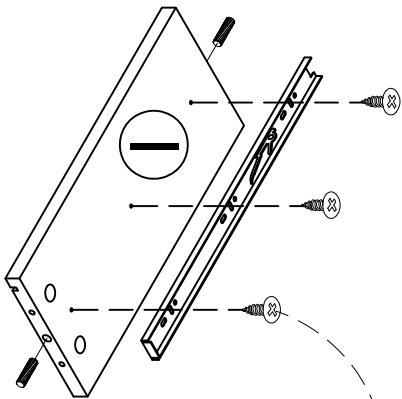
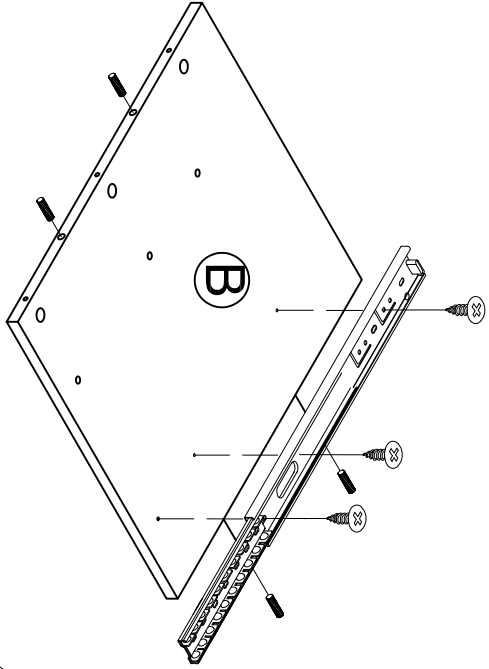
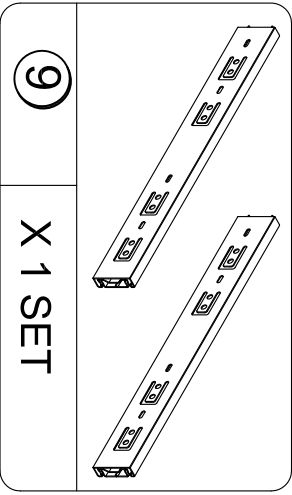
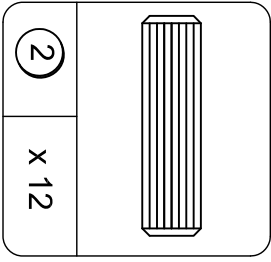
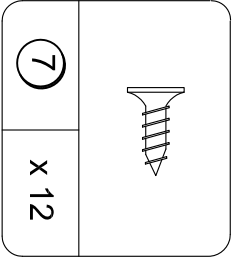



# 4

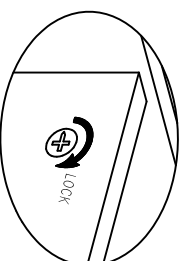
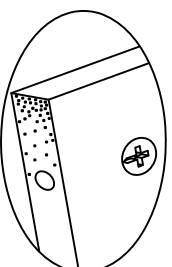
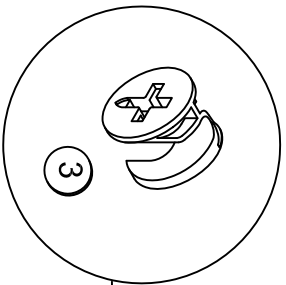
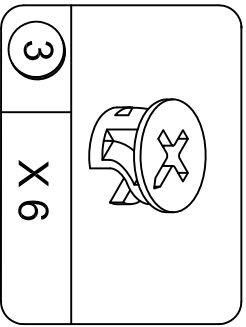
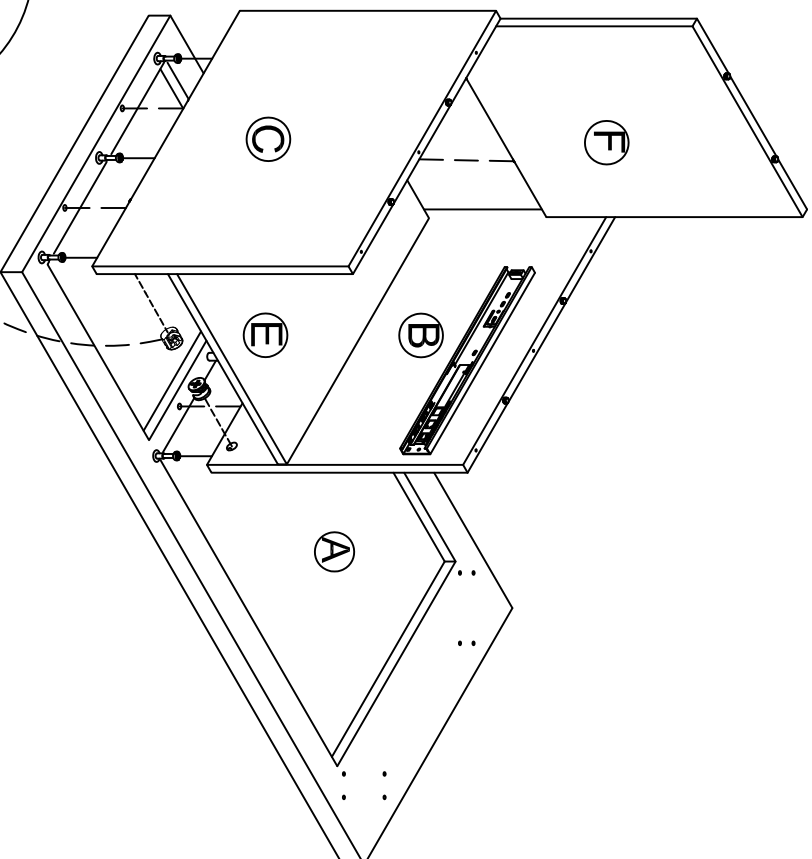
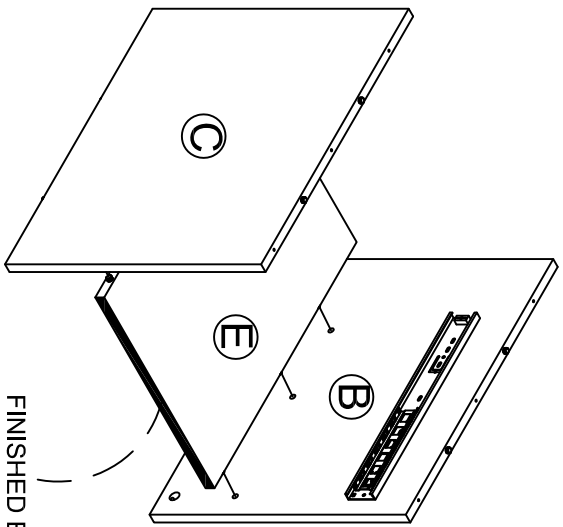

Proper orientation of CAM LOCK

# 5

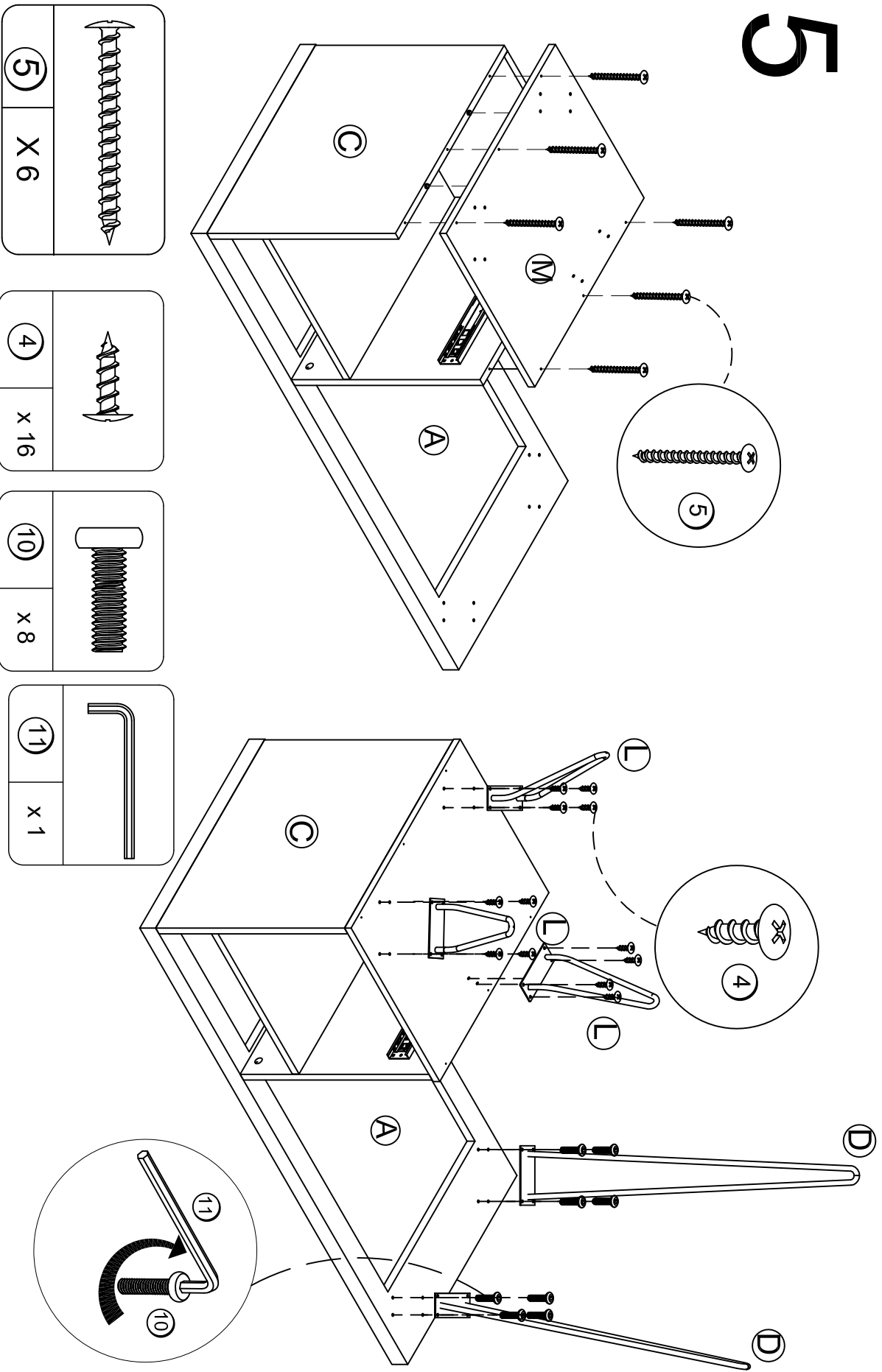

# 6

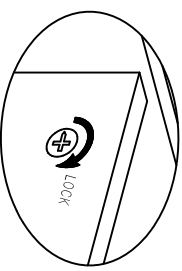
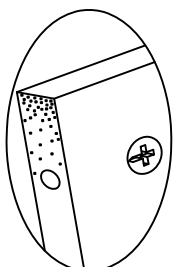
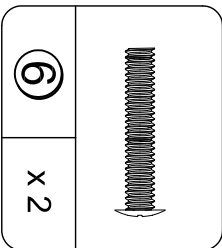
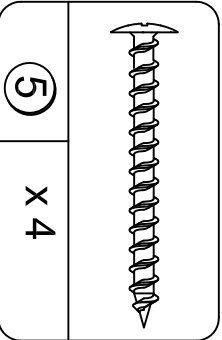
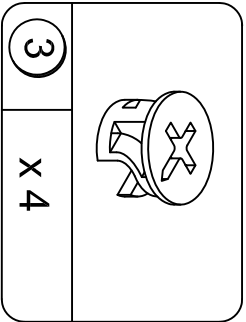
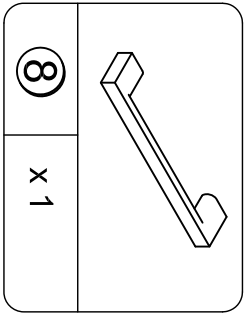
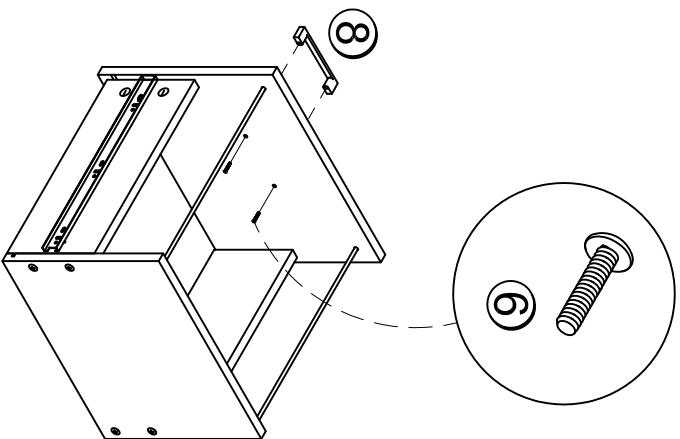
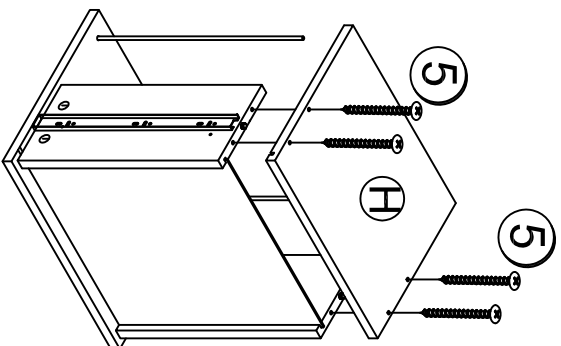
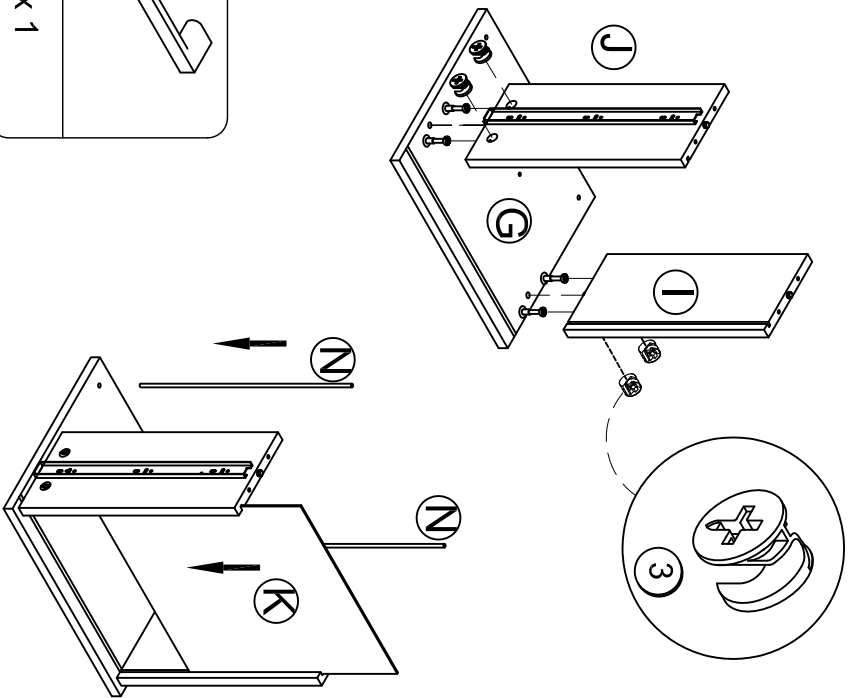

Proper orientation of CAM LOCK

**NOTE: This step is just for insert or remove drawer if needed.**

## To Insert Drawer Into Cabinet

- 1) Position anti tip mechanism, as shown.
- 2) Bring ball bearing retainer fully forward, as shown.
- 3) With help of another person, carefully align and insert drawer slide into cabinet slide, guiding the drawer slide between the ball bearing retainer, as shown.
- 4) Push the drawer into cabinet. You may experience a light resistance when pushing the drawer into cabinet but once both slides are properly engaged, drawer should slide in and out smoothly.

**NOTE:** Do not use excessive force to insert drawer as this may cause the damage to slides.

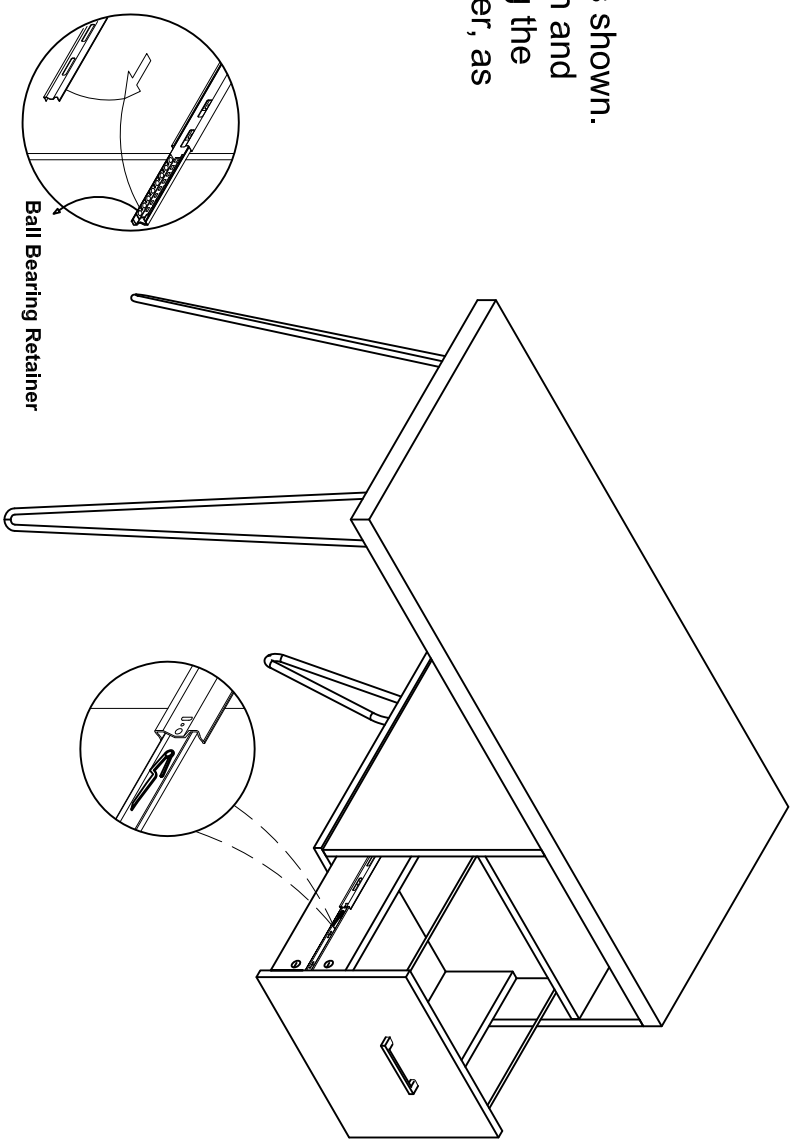

## To Remove Drawer, If Needed

- Pull the drawer fully open so levers are visible.
- Push UP on left side lever and DOWN on right side lever.
- Holding levers in place, pull drawer toward you.

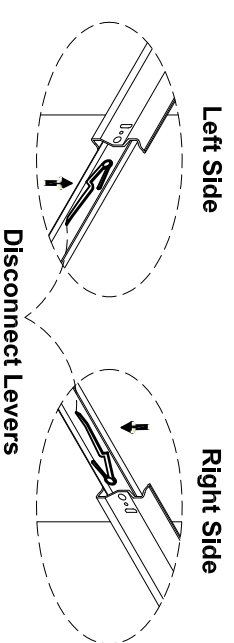

WEIGHT LIMITS :

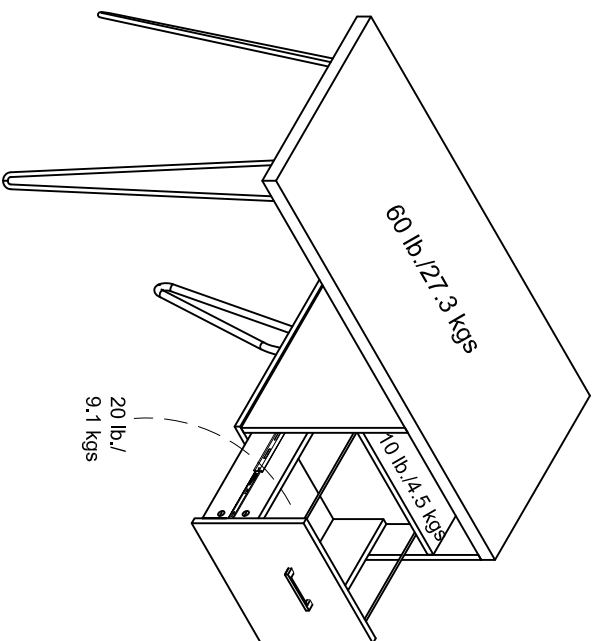

**▲ WARNING**

Please make sure that all the objects are removed before moving the assembled unit. The unit must be lifted by more than one person, not dragged or pushed. Failure to do so will cause product damage, instability, product collapse, and/or serious injury.

This unit has been designed to support the maximum loads shown. Exceeding these load limits could cause sagging, instability, product collapse, and/or serious injury.